

SLIMLINE™

OEM Reader Module
For Magnetic Stripes

90MM RAIL

OEM Reader Module
For Magnetic Stripes

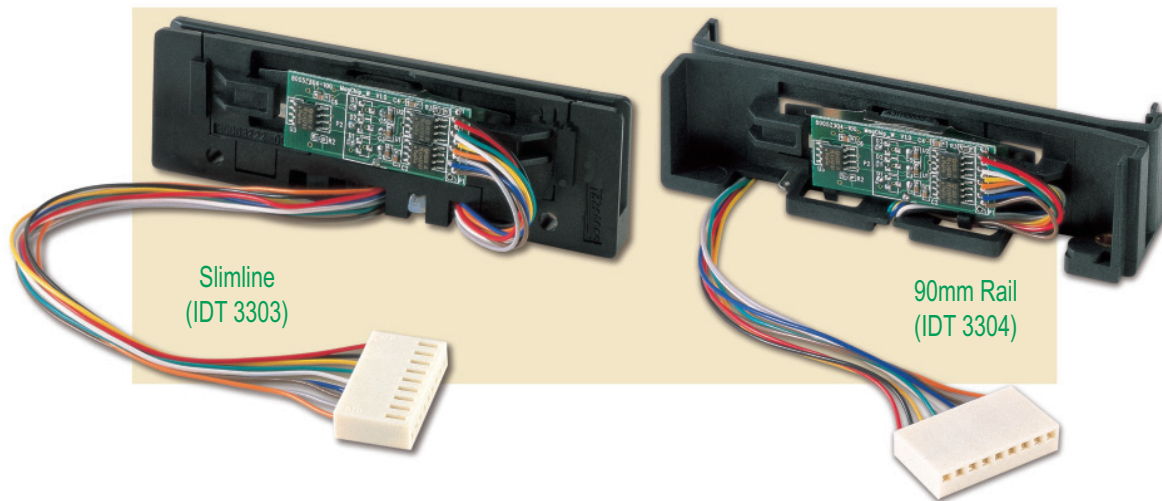

The Slimline keeps a low profile.

The Slimline magnetic stripe reader is designed for POS and portable terminal applications where space is at an absolute premium. The rail itself is just a quarter of an inch wide—ideal for mounting on the side of a keyboard or other narrow surface. Two countersunk holes are provided for easy mounting, and the accompanying electronics are attached right to the magnetic “read” head for maximum flexibility.

Reliably reads magnetic stripes.

Using ID TECH's low-power MagChip™ technology, the Slimline reads up to three tracks of data with a single swipe in either direction. Its standard-length slot makes it easy to use, with less than one error in 100,000 bits. One, two, or three-track electronics fit onto the same head-and-chip assembly. Field proven to reliably read jitter, low amplitude, and drop-out cards at 3 to 60 ips. Auto Gain Control (AGC) makes the MagChip™ technology the most reliable reader for High Coercivity cards.

Heavy-duty, versatile.

The Slimline is designed with a stainless steel wear surface to ensure long life and accurate registration. The magnetic head assembly is mounted on a wing spring that provides support, deflection, and gimble to accommodate bowed or warped cards. Its molded plastic body has a finished side that enables it to be mounted on an inside or outside surface, as well as in a cover and base.

The 90mm Rail offers same functionality as the Slimline.

The 90mm Rail delivers the same reliability and durability as the Slimline reader in a slightly wider package. The MagChip “read” head assembly provides excellent data jitter, media glitch, and drop-out immunity. Molded of rugged ABS plastic, with a stainless steel wear-plate, it is warranted for a minimum of 1,000,000 card passes. JIS compatible 90mm readers are available.

Drop-in replaceability for most POS readers.

With its standard length and variable width, the 90mm Rail is designed to retrofit over 80% of the rails in the POS market today. Two standard models (one slightly narrower than the other) and different mounting hole patterns (variable positions available with threaded inserts) make the module a drop-in replacement for such manufacturers as Panasonic, KDE, Omron, Neuron, STET, and MagTek.

IDT 3303/04 OEM Reader Module Specifications

Electrical

Magnetic:

Operation from 2.7 to 5.5 VDC. Ground 0 VDC (GND).

Chassis Ground connected to GND and magnetic head case.

True Automatic Gain Control (AGC) handles signal amplitudes from 1 mV to 1 V peak-to-peak.

Operating Current:

1.1mA per track maximum when reading a card. Less than 30 μ A when in "sleep" mode (15 μ A typical).

Communication:

TTL levels CMOS level outputs of decoded serial bits.

Environmental

Operating Temperature:

-40° F to 158° F (-35° C to 75° C). *

Storage Temperature:

-40° F to 185° F (-40° C to 85° C).

Humidity:

10% to 98% relative humidity, non-condensing.

ESD:

\pm 2000 V Electro-Static Discharge (ESD) protection.

* Does not include ice build-up on magnetic head; requires conformal coating if condensation occurs.

Reliability

Magnetic Head Life:

1,000,000 card cycles.

Rail Life:

1,000,000 card cycles.

Read Rate:

Less than one error in 100,000 bits on cards conforming to ISO 7811 1-5 (not induced by operator error).

Mechanical

Standard Decoding Densities:

Tracks 1 and 3: 210 BPI.

Track 2: 75 or 210 BPI.

Swipe Speed:

3 to 60 inches per second, bi-directional.

Card Thickness:

.01 to .045 inches.

Slot Width:

.050 (1.27mm).

Dimensions:

Slimline Rail: Length: 3.54 inches (90mm). Width: 0.63 inches (16 mm). Height: 1.10 inches (28 mm).

90mm Rail: Length: 3.54 inches (90mm). Width: 0.94 inch (24 mm). Height: 0.94 inch (24mm).

Slimline

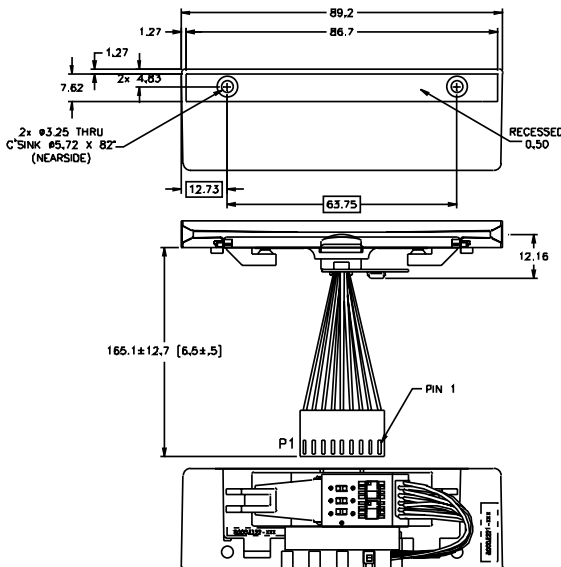

90mm Rail

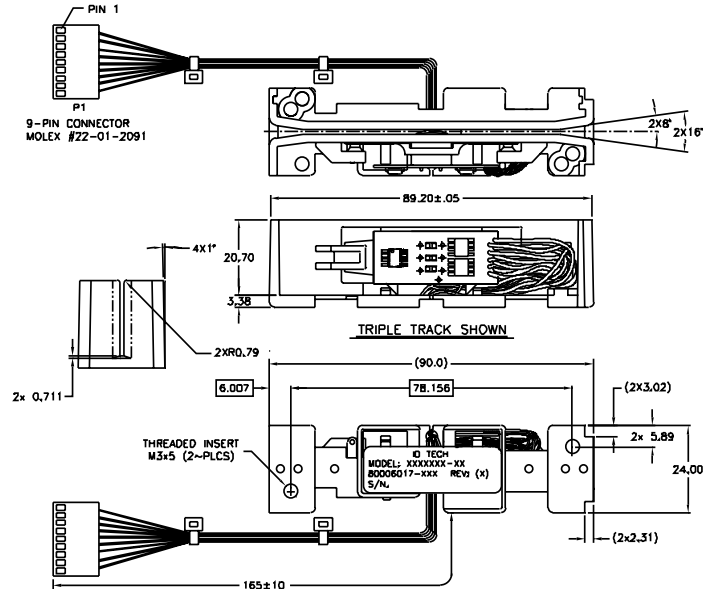

Connector Pinout

PIN	Description
1	+5V
2	Ground
3	Data Track 2
4	Clock Track 2
5	Card Present
6	Clock Track 1
7	Data Track 1
8	Clock Track 3
9	Data Track 3

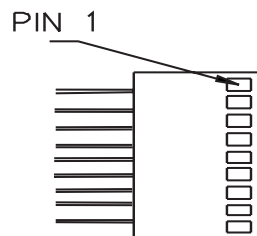

IDTECH®

Value through Innovation

10721 Walker Street

Cypress, California 90630

(714) 761-6368 Fax: (714) 761-8880

visit us at www.id-tech.net