

IDT3840-XXHL Series

Manual Swipe Magnetic Card Reader / Writer

High and/or Low Coercivity Encoding

PROGRAM MANUAL

V 1.5 March 1999

INDEX

1. INTRODUCTION	1
2. GENERAL DESCRIPTION	2
3. TECHNICAL SPECIFICATIONS.....	3
4. SETUP	5
5. UTILITIES TEST PROGRAM.....	6
6. COMMAND AND RESPONSE.....	15
7. DATA FORMAT	21
8. COMMUNICATION SEQUENCE	23
8.1 IDT3840-XXHL INITIALIZATION	23
8.2 WRITE DATA TO IDT3840-XXHL.....	23
8.3 READ DATA TO IDT3840-XXHL	24
9. ADDENDUM.....	25
(I) WRITE DATA TO MAGNETIC CARD.....	25
(II) WRITE RAW DATA TO MAGNETIC CARD	27

1. INTRODUCTION

Thank you for purchasing the IDT3840-XXHL Manual Swipe Magnetic Card Reader/Writer. It is ideal for access control, time keeping, banking, ID recognition & credit verification and related applications. In fact, wherever a magnetic stripe ID or transaction card is used, one can find a related use for the versatile, user friendly IDT3840-XXHL reader/writer.

The IDT3840-XXHL is designed to offer a reading and writing solution of high and/or low coercivity cards that will attractively complement an existing system.

This manual provides detailed information about the IDT3840-XXHL. For ease of installation and programming use, we have addressed everything from its attractive features to its various configurations.

When designing the IDT3840-XXHL, we selected what we feel are the most useful features and functions. If in some cases you find that your specific needs differ from our existing products, we welcome your comments and suggestions. Custom-designed models are also available.

This IDT3840-XXHL series has been tested and found to comply with the limits for a Class A digital device, pursuant to part 15 of the FCC Rules. These limits are designed to provide reasonable protection against harmful interference when the equipment is operated in a commercial environment.

This equipment generates, uses, and can radiate radio frequency energy and, if not installed and used in accordance with the instruction manual, may cause harmful interference to radio communications. Operation of this equipment in a residential area is likely to cause harmful interference in which case the user will be required to correct the interference at his own expense.

This IDT3840-XXHL series also had been tested and found to comply with the agency requirements of specification for CE mark Class B

EN 50 082-1	: 1992	EN 55 022	: 1994 Class B
IEC 801-2	: 1984	EN 61000-3-2	: 1995 Class A
IEC 801-3	: 1984	EN 61000-3-3	: 1995
IEC 801-4	: 1988		

Accessories of IDT3840-XXHL

Make sure all the following accessories are contained in your package:

1. Switch power Supply, AC 110~240V in / DC 24V, 2.2A out.
2. Power cord.
3. Signal cable (DB9 to RJ45, 1.5m)
4. Utility disk (A/P S/W).
5. Blank Hi-Co test card.(or and Low-Co test card)
6. User's manual

Warranty

One year after purchase of IDT3840-XXHL, any alteration and/or erasure or modification of the IDT3840-XXHL will void the warranty.

2. GENERAL DESCRIPTION

The IDT3840-XXHL series is designed to read and/or write high or low coercivity magnetic cards. It can encode and verify up to 3 tracks of data simultaneously. It communicates with a host computer or other terminal using a standard RS-232 interface.

3. TECHNICAL SPECIFICATIONS

ITEM	SPECIFICATION
Standard	ISO7811
Electrical	
Consumption	Current/operating Typical 350mA Max 600mA plus for each writing track
Communication	Standard RS232 signal voltage levels, Default, 9600 Baud, None Parity, 8 bits
Power supply	External switching Power 24V/2.2A regulated
Interconnection	
Cable	RJ45->DB9, 5 feet
Pin Assignment DB-9	1.shield
	2.TXD / IDT3840-XXHL data transmit
	3.RXD / IDT3840-XXHL data receive
	4,6,7,8,9, no connection
	5. circuit ground
Mechanical	
Body	ABS 94V-0
Swipe	Manual, single direction
Outline	210Lx68Wx60H mm
Weight	1.5Kg approx.
Environment	
Operation	-10°C to 60°C
	10 to 85% humidity, non condensing
Storage	-30°C to 70°C
	10 to 90% humidity, non condensing

Performance				
Read Circuit	Track 1&3 210bpi			
	Track 2,75 or 210 bpi			
Bit per Char	5-7 bit per char.			
Media Speed	Read, 5-50 ips (read speed 5-40 ips for track 2 at 210bpi)			
	Write, 5-30			
Media Coercivity	Read 300-4000 Oe Mag. Card			
	IDT3840-XXHC write 2750-4000 Oe Mag. Card			
	IDT3840-XXHL write 300-4000 Oe Mag. Card			
Media Thickness	0.76-1.2mm			
Jitter Card	Read bit to bit interval $\pm 15\%$ card			
	Write bit to bit interval $\pm 10\%$, Sub interval $\pm 12\%$ at 30ips			
Low amplitude Card	Read 60% for both 75& 210bpi			
Error Rate	Read < 0.5%			
	Write < 0.8%			
Media Swipe	Head life 1,000,000 passes for both read & write head			
Configuration Available Model	Model	Read/Write Track	Hi-C	Lo-C
	IDT3840-33HC	1,2&3	R/W	R
	IDT3840-12HC	1&2	R/W	R
	IDT3840-02HL	2	R/W	R/W
	IDT3840-33HL	1,2&3	R/W	R/W
	IDT3840-12HL	1&2	R/W	R/W

4. SETUP

1. Power off your system (PC).
2. Connect PC and IDT3840-XXHL as below.

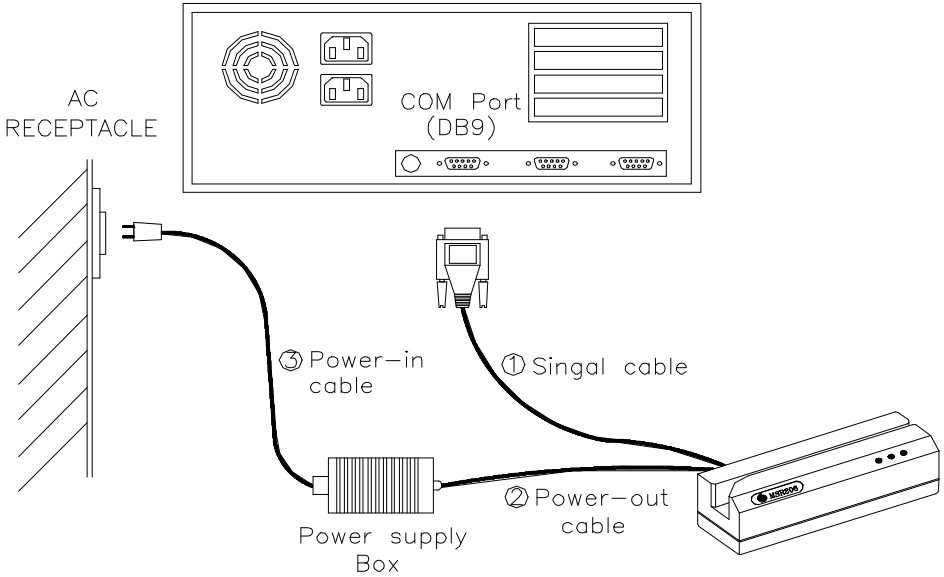

3. Connect DB9 of ① signal cable to a free serial port then connect RJ45 at the other end of the cable to IDT3840-XXHL
4. Connect outer plug of ② Power-out cable to the power inlet of IDT3840-XXHL.
5. Connect ③ Power-in cable to Power supply and AC receptacle (110V~240V).
6. Power on your system (PC).

5. UTILITIES TEST PROGRAM

Every IDT3840-XXHL comes with a utilities test program disk that includes a **Windows** version. This program is to verify and demonstrate the functionality of the IDT3840-XXHL. In some cases, it can be used as a card reading and writing test program.

5.1 System requirement

- a. 80286 PC/AT compatibles or later model with color display.
- b. DOS 3.3, WIN3.1, WIN95 or later version.
- c. 256K available conventional memory.
- d. A free serial port (Com 1 or Com 2) with DB9 male connector.

5.2 To Run the Utility Program under Windows

5.2.1

- a. Start Windows.
- b. Insert IDT3840 Utility diskette into floppy disk drive on PC.
- c. Choose **Run** from the **Start** menu bar.



- d. Windows will prompt you for the name of an application to **Run**. If the diskette is in drive A, type "A:\SETUP" and click **OK**.

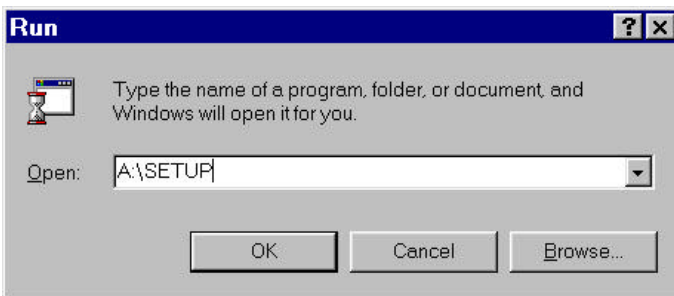

- e. The SETUP program will lead you through the installation process. The initial dialog box will be shown as below.

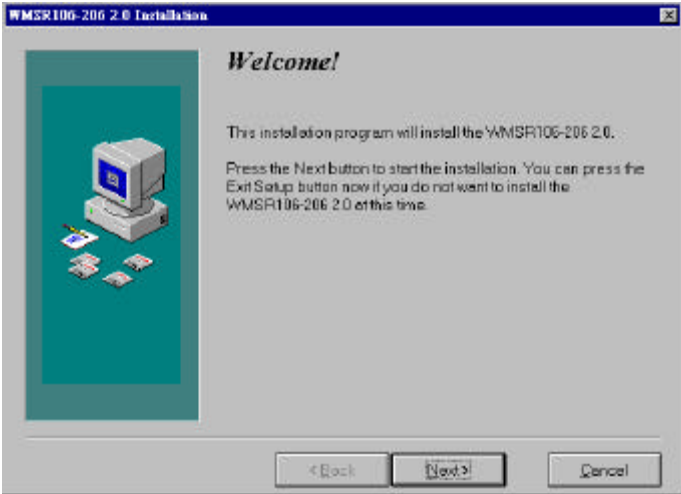

- f. Click **Next>** button, the dialog box will prompt you to choose where to install the IDT3840 testing software. If you want to change directory, click the **Browse** button to see a dialog box for choosing a new directory or type in new path name then click **Next>** to accept it.

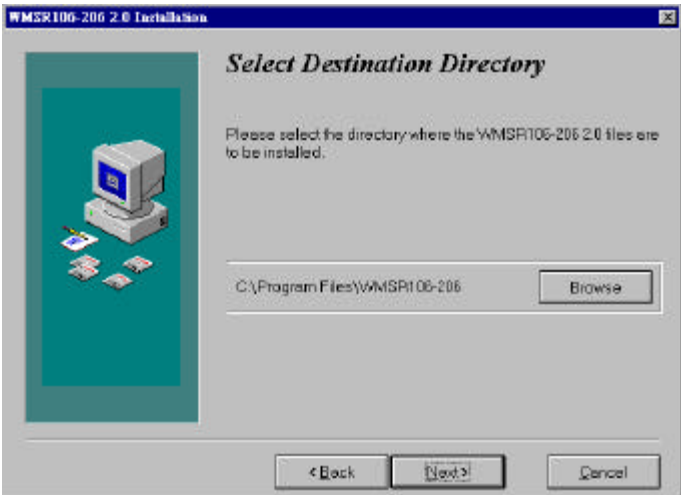

click **Next>** button again at Ready to install dialog box to start copying file to destination directory.

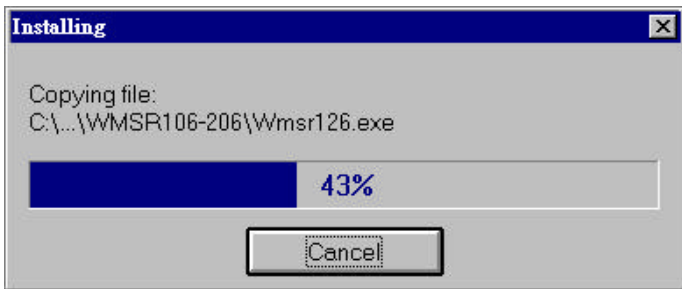

- g. Click **Finish>** button to complete installation at "Installation completed" dialog box.

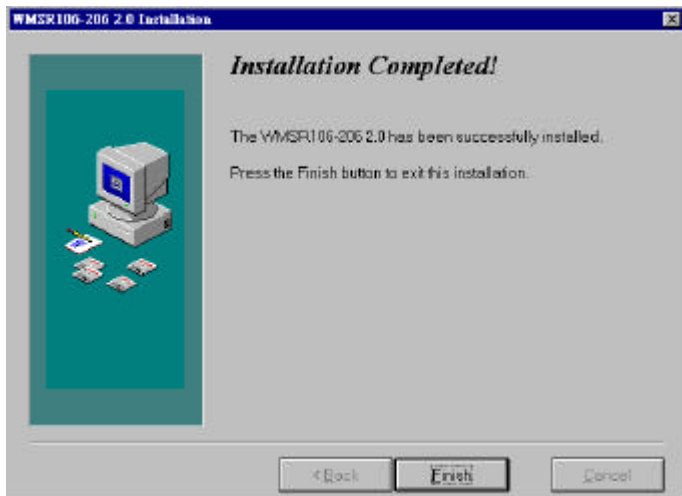

5.2.2 RUN TEST SOFTWARE

- a. Choose **Program** from **Start** menu, select **Reader_Writer** and then click on **R&W_AP** to start Test program.

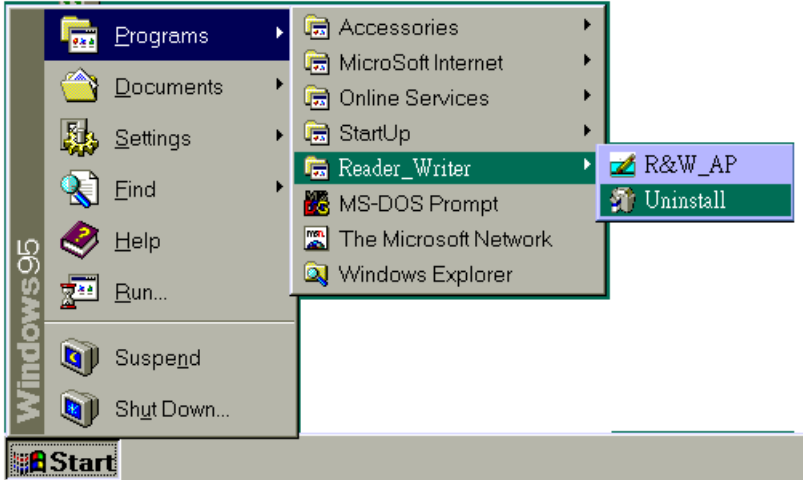

- b. If **Communication Error!!** appears in the information dialog box after opening the program, click **Setup** at main window to choose the correct COM port the MSR106 is connected to.



- c. If “**Not Found MSR106 or MSR206 !**” appears in the information dialog box after opening the program or changing the COM port, check to see that the DB9 connector is plugged into the correct COM port and the power cord/connector is also attached to DB9 thus lighting the green LED on the IDT3840

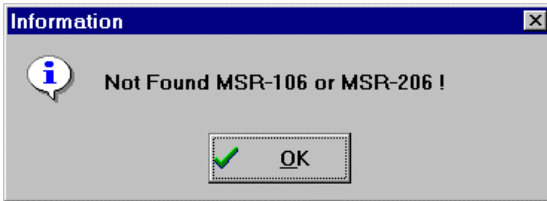

- d. When the test program is first opened, a password dialog box will ask whether you wish a first time password. If yes, enter a password of one or more characters, maximum to 16 character. And proceed to step f.



- e. If a password is not required, press ESC and a dialog box will ask you to confirm that a password is not required. Click on Yes and proceed to demo program.

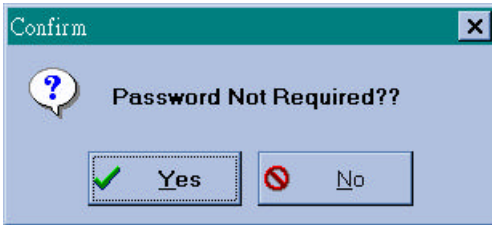

- f. When entering a password for the first time, the system will require you to confirm the password, Click **OK**, after you reenter your password.

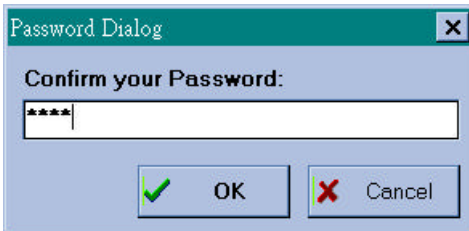

* Remember the password you entered, because if it is forgotten, you must re-install the Test Program.

* Remember, however; should you desire password protection in the future, you must re-install the program.

- g. When the Test Program is opened, you'll see the main window of the READER/WRITER UTILITY PROGRAM.

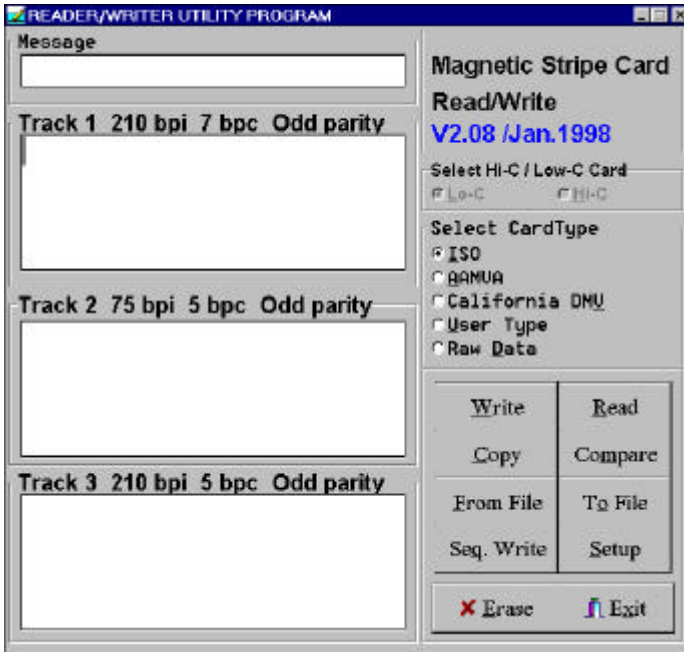

From this main window you can activate all functions by clicking the appropriate buttons and following the on screen instructions.

The Test Program will auto detect whether a IDT3840 is connected. For the IDT3840 unit you may click at the **Select Hi-C/Low-C Card** column either Lo-C (low coercivity, 300~600 Oe) or Hi-C (high coercivity, 2750~4000 Oe).

- h. By clicking **Setup** from main window, you can change COM ports, Leading Zeros for all 3 tracks and BPI of track 2.

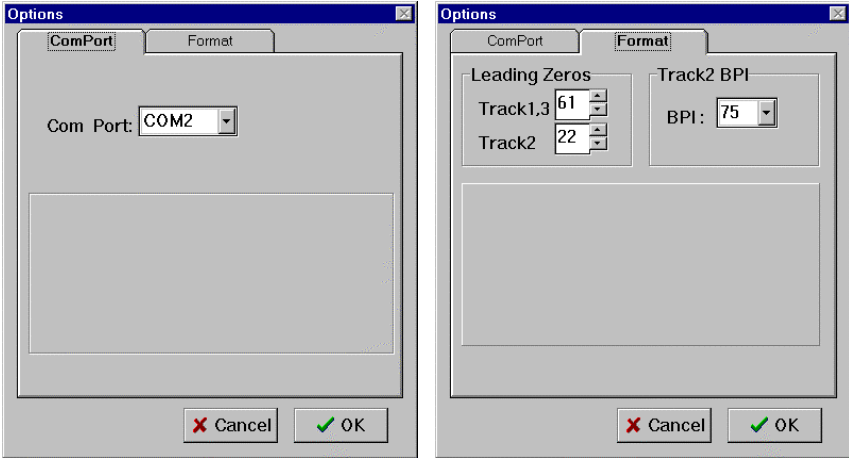

- i. By choosing **User Type** from the main window, you can then define your user parameters by clicking **Setup** & selecting **User Type**.

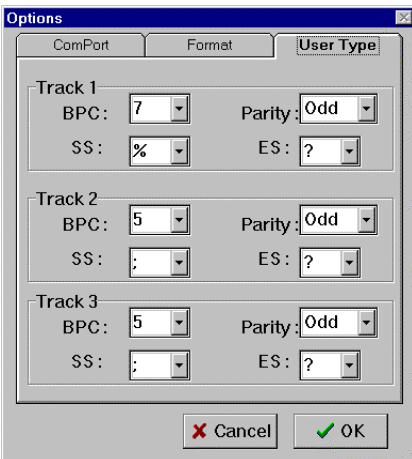

6. COMMAND and RESPONSE

This section gives detailed description of commands to the IDT3840-XXHL and the corresponding response from IDT3840-XXHL.

Notional Conventions:

<ESC>	Control character named
[sname]	Special string named sname, meaning can be found in section 7. ie.[Data Block] [Status Byte] [Select Byte] etc.
X	Standard ANSI character

Command Description:

1. Command : **RESET**
Command code : <ESC> a
Hex code : 1B 61
Response : none
Description : This command reset the IDT3840-XXHL to initial state.
2. Command : **READ**
Command code : <ESC> r
Hex code : 1B 72
Response : [Data Block] <ESC> [Status Byte]
Description : This command request IDT3840-XXHL to read a card swiped and respond with the data read.
3. Command : **WRITE**
Command code : <ESC> w [Data Block]
Hex code : 1B 77 [Data Block]
Response : <ESC> [Status Byte]
Description : This command request IDT3840-XXHL to write the Data Block into the card swiped.

4. Command : **Communication test**
 Command code : <ESC> e
 Hex code : 1B 65
 Response : <ESC> y [1B] [79]
 Description : This command is used to verify that the communication link between computer and IDT3840-XXHL is up and good.
5. Command : **All LED off**
 Command code : <ESC> <81>
 Hex code : 1B 81
 Response : none
 Description : This command is used to turn off all the LEDs.
6. Command : **All LED on**
 Command code : <ESC> <82>
 Hex code : 1B 82
 Response : none
 Description : This command is used to turn on all the LEDs.
7. Command : **GREEN LED on**
 Command code : <ESC> <83>
 Hex code : 1B 83
 Response : none
 Description : This command is used to turn on Green LED.
8. Command : **YELLOW LED on**
 Command code : <ESC> <84>
 Hex code : 1B 84
 Response : none
 Description : This command is used to turn on the Yellow LED.
9. Command : **RED LED on**
 Command code : <ESC> <85>
 Hex code : 1B 85
 Response : none
 Description : This command is used to turn on the Red LED.

10. Command : **Sensor test**
 Command code : <ESC> <86>
 Hex code : 1B 86
 Response : <ESC> 0 (1B 30) if test ok
 Description : This command is used to verify that the card sensing circuit of IDT3840-XXHL is working properly IDT3840-XXHL will not response until a card is sensed or receive a RESET command.
11. Command : **Ram test**
 Command code : <ESC> <87>
 Hex code : 1B 87
 Response : <ESC> 0 (1B 30) ram test ok
 <ESC> A (1B 41) ram test fail
 Description : This command is used to request IDT3840-XXHL to perform a test on its on board RAM.
12. Command : **Set leading zero**
 Command code : <ESC> z [leading zero of track 1 & 3] [leading zero of track 2]
 Hex code : 1B 7A [00~ff] [00~ff]
 Response : <ESC> 0 (1B 30) set ok
 <ESC> A (1B 41) set fail
 Description : This command is used to set how many leading zeros will be written before the card data starts, and the space should calculated as
 [leading zero] X25.4 / BPI (75or210) =mm
 Default setting of leading zero: [3D] [16]
 TK1 & TK3: [3D] means leading zero=61
 TK2: [16] means leading zero=22
13. Command : **Check leading zero**
 Command code : <ESC> l
 Hex code : 1B 6C
 Response : 1B [00~ff] [00~ff]
 Description : This command is used to ask IDT3840-XXHL the present setting number of leading zeros.

14. Command : **Erase card**
 Command code : <ESC> c [Select Byte]
 Hex code : 1B 63 [Select Byte]
 Response : <ESC> 0 [1B] [30] command Select Byte ok
 <ESC> A [1B] [41] command Select Byte fail
 Description : This command is used to erase the card data when
 card swipe.
 *[Select Byte] format :
 00000000 : Track 1 only
 00000010 : Track 2 only
 00000100 : Track 3 only
 00000011 : Track 1 & 2
 00000101 : Track 1 & 3
 00000110 : Track 2 & 3
 00000111 : Track 1, 2 & 3
15. Command : **Select BPI** (only for TK2)
 Command code : <ESC> b [Density]
 Hex code : 1B 62 [D2 or 4B]
 Response : <ESC> 0 [1B] [30] select ok
 <ESC> A [1B] [41] select fail
 Description : This command is used to select the density of TK2.
 [D2] : TK2 BPI=210 [4B] : TK2 BPI=75
16. Command : **Read raw data**
 Command code : <ESC> m
 Hex code : 1B 6D
 Response : [Raw Data Block] <ESC> [Status Byte]
 Description : This command requests IDT3840-XXHL to
 read a card swipe but send without ASCII decode.
Refer to [Raw Data Block] & [Raw Data] format.
17. Command : **Write raw data**
 Command code : <ESC> n [Raw Data Block]
 Hex code : 1B 6E [Raw Data Block]
 Response : <ESC> [Status Byte]
 Description : This command requests IDT3840-XXHL to
 write raw Data Block into the card swiped.
Refer to [Raw Data Block] & [Raw Data] format.

18. Command : **Get device model**
 Command code : <ESC> t
 Hex code : 1B 74
 Response : <ESC> [Model] S
 Description : This command is used to get the model of IDT3840-XXHL. There are four models

Models	Description
IDT3840-02HL	Track 2
IDT3840-23HL	Track 2 & 3
IDT3840-33HL	Track 1,2 & 3
IDT3840-12HL	Track 1 & 2

19. Command : **Get firmware version**
 Command code : <ESC> v
 Hex code : <ESC> 76
 Response : <ESC> [version]
 Description : This command can get the firmware version of IDT3840-XXHL.

* [version] is a 5 bytes version number, format is " REV?X.XX "

IDT3840-XX ? = 0
 IDT3840-XXHC ? = H
 IDT3840-XXHL ? = U

20. Command : **Set BPC**
 Command code : <ESC> o [tk1bit][tk2bit][tk3bit]
 Hex code : <ESC> 6F [05-08][05-08][05-08]
 Response : <ESC> 30 [tk1bit][tk2bit][tk3bit]
 Description : This command is used to set the bit per character of every track.

21. Command : **Set Hi-Co**
 Command code : <ESC> x
 Hex code : 1B 78
 Response : <ESC> 0
 Description : This command is used to set IDT3840-XXHL status to write Hi-Co card.
22. Command : **Set Low-Co**
 Command code : <ESC> y
 Hex code : 1B 79
 Response : <ESC> 0
 Description : This command is used to set IDT3840-XXHL status to write Low-Co card.
23. Command : **Get Hi-Co or Low-Co status**
 Command code : <ESC> d
 Hex code : 1B 64
 Response : <ESC> H -----to write Hi-Co
 : <ESC> L ----- to write Low-Co
 Description : This command is to get IDT3840-XXHL write status

7. DATA FORMAT

- **[Data Block]** format:

	Start Field	R/W Data Field	Ending Field
Command code	<ESC> s	[Card data]	? <FS>]
Hex code	1B 73	[Card data]	3F 1C]

- **[Card data]** format:

	Card Data
Char Code	<ESC> 1[string1] <ESC> 2 [string2] <ESC> 3 [string3]
Hex Code	1B 01 [string1] 1B 02 [string2] 1B 03 [string3]

- **[Status Byte]** format:

Status	description	HEX	ASCII
Ok	If read, write or command ok	30h	0
Error	Write or read error	31h	1
	Command format error	32h	2
	Invalid command	34h	4
	Invalid card swipe when in write mode	39h	9

* Note:

1. When [Status Byte] equal 39h means card moving error
2. None available and none data tracks will not be transmitted when swipe of card.

*For example, when read card with data encoded on track 2 only for IDT3840-XXH, it will transmit data like **1B 73 1B 01 1B 02 [string] 3F 1C**, for no data on track 1 so it shown 1B 01 only.*

- **[Raw Data Block]** format :

	Start Field	R/W Data Field	Ending Field
Command code	<ESC> s	[Raw data]	? <FS>]
Hex code	1B 73	[Raw data]	3F 1C]

- **[Raw Data]** format :

	Raw Data
Char Code	<ESC>1[L1][string1]<ESC>2[L2][string2]<ESC>3[L3][string3]
Hex Code	1B 01[L1][string1]1B 02[L2][string2]1B 03[L3][string3]

Note:

1. [L1],[L2],[L3] is the length of [string1],[string2],and [string3]
2. None available and none data tracks will not output when swipe of card,

For example, when read card (encoded data on track 2 only) on IDT3840-XXHL, it will transmit data like

1B 73 1B 01 00 1B 02 [L2] [string] 3F 1C

- **[Raw Data]** bit orientation :

Track 1 for 8 BPC

Read

$\overline{B_0} \overline{B_1} \overline{B_2} \overline{B_3} \overline{B_4} \overline{B_5} \overline{B_6} \overline{B_7} \overline{B_1} \overline{B_2} \overline{B_3} \overline{B_4} \overline{B_5} \overline{B_6} \overline{B_7} \overline{B_0} \overline{B_1} \overline{B_2} \overline{B_3} \overline{B_4} \overline{B_5} \overline{B_6} \overline{B_7} \overline{B_0} \overline{B_1} \overline{B_2}$

Write

$\overline{B_0} \overline{B_6} \overline{B_5} \overline{B_4} \overline{B_3} \overline{B_2} \overline{B_1} \overline{B_0} \overline{B_1} \overline{B_0} \overline{B_6} \overline{B_5} \overline{B_4} \overline{B_3} \overline{B_2} \overline{B_1} \overline{B_0} \overline{B_1} \overline{B_0} \overline{B_6} \overline{B_5} \overline{B_4} \overline{B_3} \overline{B_2}$

Track 2 & 3 for 8 BPC

Read

$\overline{B_0} \overline{B_1} \overline{B_2} \overline{B_3} \overline{B_4} \overline{B_0} \overline{B_1} \overline{B_2} \overline{B_3} \overline{B_4} \overline{B_0} \overline{B_1} \overline{B_2} \overline{B_3} \overline{B_4} \overline{B_0} \overline{B_1} \overline{B_2} \overline{B_3} \overline{B_4} \overline{B_0} \overline{B_1} \overline{B_2} \overline{B_3}$

Write

$\overline{B_2} \overline{B_1} \overline{B_0} \overline{B_4} \overline{B_3} \overline{B_2} \overline{B_1} \overline{B_0} \overline{B_4} \overline{B_3} \overline{B_2} \overline{B_1} \overline{B_0} \overline{B_4} \overline{B_3} \overline{B_2} \overline{B_1} \overline{B_0} \overline{B_4} \overline{B_3} \overline{B_2} \overline{B_1} \overline{B_0} \overline{B_4} \overline{B_3}$

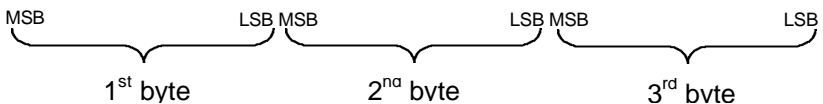

*Refer to 9.ADDENDUM

8. COMMUNICATION SEQUENCE

The examples below assumes data on track1, 2 & 3 to be 01, 23, 45 respectively

8.1 IDT3840-XXHL INITIALIZATION

HOST	Direction	IDT3840
Command code: <ESC>a HEX code: [1B][61]	→	(Reset)
Command code: <ESC>e HEX code: [1B][65]	→	(Serial port test)
	←	Command test ACK:<ESC>y HEX code:[1B][79]
Command code <ESC>a HEX code: [1B][61]	→	(Reset)

8.2 WRITE DATA TO IDT3840-XXHL

HOST	Direction	IDT3840
Command code: <ESC>w<ESC>s<ESC>[01]01 <ESC>[02]23<ESC>[03]45?<FS> HEX code: [1B][77][1B][73][1B][01][30][31][1B] [02][32][33][1B][03][34][35][3F][1C]	(write command) →	
	(status ACK) ←	(Wait until swipe card) Command ACK:<ESC> <status> HEX code:[1B][status] Status =[30] no error Status =[31]~[3F] if error

8.3 READ DATA TO IDT3840-XXHL

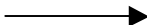
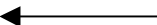
HOST	Direction	IDT3840
Command code:<ESC>r HEX code: [1B][72]	(read command) 	
	(status ACK) 	(Wait until swipe card) Command ACK: <ESC>s<ESC>[01]%01?<ESC>[02];23?<ESC>[03];45??<FS><ESC><status> HEX code: [1B][73][1B][01][25][30][31][3F][1B][02][3B][32][33][3F][1B][03][3B][34][35][3F][3F][1C][1B][status] Status=[30] ok Status=[31]~[3F] if error

* [XX] = HEX Code XX

9. ADDENDUM

(I) WRITE DATA TO MAGNETIC CARD

The WRITE command:

Command	WRITE
Command code	<ESC> w [<i>Data Block</i>]
Hex code	1B 77 [<i>Data Block</i>]
Response	<ESC> [Status Byte]
Description	This command request IDT3840-XXHL to write the Data Block into the card swiped.

[*Data Block*] format:

	Start Field	R/W Data Field	Ending Field
Command code	<ESC>s	[<i>card data</i>]	?<FS>
HEX code	1B 73	[<i>card data</i>]	3F 1C

[*card data*] format:

	card data
Char. code	<ESC>[01] [string] <ESC> [02] [string] <ESC> [03] [string3]
HEX code	1B 01 [string1] 1B 02 [string2] 1B 03 [string3]

As an example the following information will be write to the card:

Track1: %ABC123?

Track2: ;12345?

Track3: ;12345?

HOST	DIRECTION	IDT3840-XXHL
Command code: <esc>w<ESC>s<ESC>[01]ABC123<ESC>[02]12345<ESC>[03]12345?<FS> HEX code: [1B][77][1B][73][1B][01][41][42][43][31][32][33][1B][02][31][32][33][34][35][1B][03][31][32][33][34][35][3F][1C]	(write command) ----->	
After send command to IDT3840	Yellow LED on, then swipe card	write data to the magnetic card
	(status ACK)	(wait until swipe card) Command ACK:<ESC><status> HEX code:[1B][status] Status = [30] no error Status = [31] ~ [3F] if error

(II) WRITE RAW DATA TO MAGNETIC CARD

Converting Card Data Information to Hexadecimal for the Binary Write Function

Converting track one ASCII information into HEX

					0	1	2	3
				B5	0	0	1	1
	B3	B2	B1	B0 B4	0	1	0	1
0	0	0	0	0	(sp)	0	2	P
1	0	0	0	1	!	1	A	Q
2	0	0	1	0	"	2	B	R
3	0	0	1	1	#	3	C	S
4	0	1	0	0	\$	4	D	T
5	0	1	0	1	%	5	E	U
6	0	1	1	0	&	6	F	V
7	0	1	1	1	'	7	G	W
8	1	0	0	0	(8	H	X
9	1	0	0	1)	9	I	Y
A	1	0	1	0	*	:	J	Z
B	1	0	1	1	+	;	K	[
C	1	1	0	0	`	<	L	\
D	1	1	0	1	,	=	M]
E	1	1	1	0	.	>	N	^
F	1	1	1	1	/	?	O	_

Converting track two and three ASCII information into HEX

Data	p	B3	B2	B1	B0
0	1	0	0	0	0
1	0	0	0	0	1
2	0	0	0	1	0
3	1	0	0	1	1
4	0	0	1	0	0
5	1	0	1	0	1
6	1	0	1	1	0
7	0	0	1	1	1
8	0	1	0	0	0
9	1	1	0	0	1
:	1	1	0	1	0
: (*)	0	1	0	1	1
<	1	1	1	0	0
=	0	1	1	0	1
>	0	1	1	1	0
? (*)	1	1	1	1	1

As a example the following information will be write to the card:

Track1: %ABC123?

Track2: ;12345?

Track3: ;12345?

We use three different data bits to write raw data on the cards. The procedures are listed as below:

08, 08, 08 BITS

1. Set each track as 08.
First of all, set BPC command:
1B, 6F, 08, 08, 08
2. Present the information to the card encoder, as follows:

FIELD NAME	HEX CODE
Start Field	1B6E1B73
Track1 header	1B01
Length	08
Track1 data	C5B07814954E3E2A
Track header	1B02
Length	05
Track2 data	2B8849EAAF
Track3 header	1B03
Length	05
Track3 data	2B8849EAAF
Ending Field	3F1C

Transfer the track1 data to HEX under 08 bits:

	B0	B1	B2	B3	B4	B5	P
%	1	0	1	0	0	0	1
A	1	0	0	0	0	1	1
B	0	1	0	0	0	1	1
C	1	1	0	0	0	1	0
1	1	0	0	0	1	0	1
2	0	1	0	0	1	0	1
3	1	1	0	0	1	0	0
?	1	1	1	1	1	0	0
LRC	0	1	0	1	0	1	0

Calculate Odd Parity (P column)

If there are an Even Number of 1's in the row of data for each character, put a 1 in the P column. Other wise, put a 0 in the column.

LRC: If there are an Even Number of 1's in the column of data for each character, put a 0 in the LRC row. Other wise, put a 0 in the row. The last LRC will be considered as the parity rule of this row.

B0	B1	B2	B3	B4	B5	B6	B7	
1	0	1	0	0	0	1	1	
0	0	0	0	1	1	0	1	
0	0	0	1	1	1	1	0	
0	0	1	0	1	0	0	0	
1	0	1	0	1	0	0	1	
0	1	1	1	0	0	1	0	
0	1	1	1	1	1	0	0	
0	1	0	1	0	1	0	0	

B7	B6	B5	B4	B3	B2	B1	B0	HEX
1	1	0	0	0	1	0	1	C5
1	0	1	1	0	0	0	0	B0
0	1	1	1	1	0	0	0	78
0	0	0	1	0	1	0	0	14
1	0	0	1	0	1	0	1	95
0	1	0	0	1	1	1	0	4E
0	0	1	1	1	1	1	0	3E
0	0	1	0	1	0	1	0	2A

Transfer track 2 (track 3) data to HEX under 08 bits:

	B0	B1	B2	B3	P
;	1	1	0	1	0
1	1	0	0	0	0
2	0	1	0	0	0
3	1	1	0	0	1
4	0	0	1	0	0
5	1	0	1	0	1
?	1	1	1	1	1
LRC	1	0	1	0	1

B0	B1	B2	B3	B4	B5	B6	B7
1	1	0	1	0	1	0	0
0	0	0	1	0	0	0	1
1	0	0	1	0	0	1	0
0	1	0	1	0	1	1	1
1	1	1	1	0	1	0	1

B7	B6	B5	B4	B3	B2	B1	B0	HEX
0	0	1	0	1	0	1	1	2B
1	0	0	0	1	0	0	0	88
0	1	0	0	1	0	0	1	49
1	1	1	0	1	0	1	0	EA
1	0	1	0	1	1	1	1	AF

07, 05, 05 BITS

Set TK1, TK2 & TK3 as 07, 05, 05

- 1b, 6F, 07, 05, 05
First of all, set BPI command:
2. Present the information to the card encoder, as follows:

FIELD NAME	HEX CODE
Start Field	1B6E1B73
Track1 header	1B01
Length	09
Track1 data	456162235152131F2A
Track2 header	1B02
Length	08
Track2 data	0B01021304151F15
Track3 header	1B03
Length	08
Track3 data	0B01021304151F15
Ending Field	3F1C

Transfer the track1 data to HEX under 07 bits:

	B0	B1	B2	B3	B4	B5	P
%	1	0	1	0	0	0	1
A	1	0	0	0	0	1	1
B	0	1	0	0	0	1	1
C	1	1	0	0	0	1	0
1	1	0	0	0	1	0	1
2	0	1	0	0	1	0	1
3	1	1	0	0	1	0	0
?	1	1	1	1	1	0	0
LRC	0	1	0	1	0	1	0

Calculate Odd Parity (P column)

If there are an Even Number of 1's in the row of data for each character, put a 1 in the P column. Other wise, put a 0 in the column.

	Add	P	B5	B4	B3	B2	B1	B0	HEX
%	0	1	0	0	0	1	0	1	45
A	0	1	1	0	0	0	0	1	61
B	0	1	1	0	0	0	1	0	62
C	0	0	1	0	0	0	1	1	23
1	0	1	0	1	0	0	0	1	51
2	0	1	0	1	0	0	1	0	52
3	0	0	0	1	0	0	1	1	13
?	0	0	0	1	1	1	1	1	1F
LRC	0	0	1	0	1	0	1	0	2A

HEX

	B3	B2	B1	B0
0	0	0	0	0
1	0	0	0	1
2	0	0	1	0
3	0	0	1	1
4	0	1	0	0
5	0	1	0	1
6	0	1	1	0
7	0	1	1	1
8	1	0	0	0
9	1	0	0	1
A	1	0	1	0
B	1	0	1	1
C	1	1	0	0
D	1	1	0	1
E	1	1	1	0
F	1	1	1	1

Transfer track 2 (track 3) data to HEX under 05 bits:

	B0	B1	B2	B3	P
;	1	1	0	1	0
1	1	0	0	0	0
2	0	1	0	0	0
3	1	1	0	0	1
4	0	0	1	0	0
5	1	0	1	0	1
?	1	1	1	1	1
LRC	1	0	1	0	1

	Add 0	Add 0	Add 0	P	B3	B2	B1	B0	HEX
;	0	0	0	0	1	0	1	1	0B
1	0	0	0	0	0	0	0	1	01
2	0	0	0	0	0	0	1	0	02
3	0	0	0	1	0	0	1	1	13
4	0	0	0	0	0	1	0	0	04
5	0	0	0	1	0	1	0	1	15
?	0	0	0	1	1	1	1	1	1F
LRC	0	0	0	1	0	1	0	1	15

06, 05, 06 BITS

3. Set TK1, TK2 & TK3 as 06, 05, 06
First of all, set BPI command:
1b, 6F, 06, 05, 06
4. Present the information to the card encoder, as follows:

UIC	
Start Field	1B6E1B73
Track1 header	1B01
Length	09
Track1 data	052122231112131F2A
Track2 header	1B02
Length	08
Track2 data	0B01021304151F15
Track3 header	1B03
Length	08
Track3 data	0101020304051F1F
Ending Field	3F1C

Transfer track1 data to HEX under 06 bits:

	B0	B1	B2	B3	B4	B5
%	1	0	1	0	0	0
A	1	0	0	0	0	1
B	0	1	0	0	0	1
C	1	1	0	0	0	1
1	1	0	0	0	1	0
2	0	1	0	0	1	0
3	1	1	0	0	1	0
?	1	1	1	1	1	0
LRC	0	1	0	1	0	1

	Add 0	Add 0	B5	B4	B3	B2	B1	B0	HEX
%	0	0	0	0	0	1	0	1	05
A	0	0	1	0	0	0	0	1	21
B	0	0	1	0	0	0	1	0	22
C	0	0	1	0	0	0	1	1	23
1	0	0	0	1	0	0	0	1	11
2	0	0	0	1	0	0	1	0	12
3	0	0	0	1	0	0	1	1	13
?	0	0	0	1	1	1	1	1	1F
LRC	0	0	1	0	1	0	1	0	2A

Transfer track 2 data to HEX under 05 bits:

	B0	B1	B2	B3	P
;	1	1	0	1	0
1	1	0	0	0	0
2	0	1	0	0	0
3	1	1	0	0	1
4	0	0	1	0	0
5	1	0	1	0	1
?	1	1	1	1	1
LRC	1	0	1	0	1

	Add 0	Add 0	Add 0	P	B3	B2	B1	B0	HEX
;	0	0	0	0	1	0	1	1	0B
1	0	0	0	0	0	0	0	1	01
2	0	0	0	0	0	0	1	0	02
3	0	0	0	1	0	0	1	1	13
4	0	0	0	0	0	1	0	0	04
5	0	0	0	1	0	1	0	1	15
?	0	0	0	1	1	1	1	1	1F
LRC	0	0	0	1	0	1	0	1	15

Transfer track 3 data to HEX under 06 bits:

	B0	B1	B2	B3	B4	B5
!	1	0	0	0	0	0
1	1	0	0	0	0	0
2	0	1	0	0	0	0
3	1	1	0	0	0	0
4	0	0	1	0	0	0
5	1	0	1	0	0	0
?	1	1	1	1	1	0
LRC	1	1	1	1	1	0

	Add 0	Add 0	B5	B4	B3	B2	B1	B0	HEX
!	0	0	0	0	0	0	0	1	01
1	0	0	0	0	0	0	0	1	01
2	0	0	0	0	0	0	1	0	02
3	0	0	0	0	0	0	1	1	03
4	0	0	0	0	0	1	0	0	04
5	0	0	0	0	0	1	0	1	05
?	0	0	0	1	1	1	1	1	1F
LRC	0	0	0	1	1	1	1	1	1F